

[AT-SFP-B1213L-20-1310](#)

[AT-SFP-B1213L-20-1550](#)

Optical SFP Module

1.25Gbps SFP Transceiver Bi di TX1550/RX1310nm 20km LC



FEARTURES

- Up to 1.25Gbps data links
- 1550nm FP laser and photo PIN detector for 20km transmission
- Compliant with SFP MSA and SFF-8472 with Duplex LC receptacle
- Digital Diagnostic Monitoring: Internal Calibration or External Calibration
- +3.3V single power supply
- Compatible with SONET
- Compatible with RoHS
- Operating case temperature: Standard :0 to +70° C Industrial : -40 to +85° C

APPLICATION

- SDH and SONET system
- Fiber Channel
- Switch to Switch interface
- Switched backplane applications
- Router/Server interface
- Other optical transmission systems

STANDARD

- Compliant with MSA SFP specification
- Compliant with IEC
- Compliant with IEEE 802.3z

DESCRIPTION

The SFP transceivers are high performance, cost effective modules supporting dual data-rate of 1.25Gbps and 20km transmission distance with SMF.

The transceiver consists of three sections: a FP laser transmitter, a PIN photodiode integrated with a trans-impedance preamplifier (TIA) and MCU control unit. All modules satisfy class I laser safety requirements.

The transceivers are compatible with SFP Multi-Source Agreement (MSA). For further information, please refer to SFP MSA.

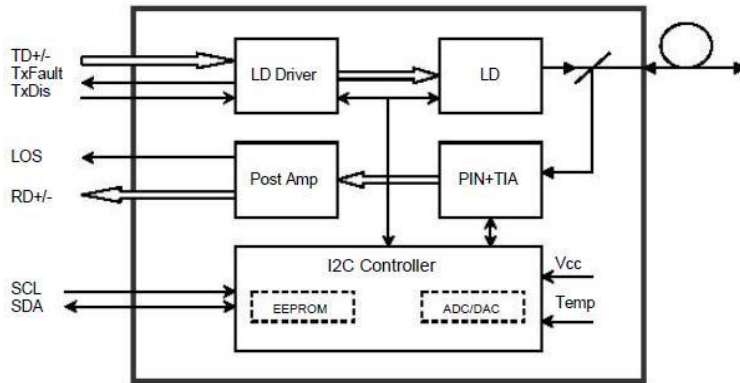

ABSOLUTE MAXIMUM RATINGS

Parameter	Symbol	Min	Max	Unit
Supply Voltage	Vcc	0	4	V
Storage Temperature	Ts	-40	+85	°C
Operating Humidity	-	5	85	%

RECOMMENDED OPERATING CONDITIONS

Parameter	Symbol	Min	Typical	Max	Unit
Operating Case Temperature	Tc	0		+70	°C
		-40		+85	°C
Power Supply Voltage	Vcc	3.13	3.3	3.47	V
Power Supply Current	Icc			300	mA
Data Rate			1.25		Gbps

OPTICAL AND ELECTRICAL CHARACTERISTICS

Parameter	Symbol	Min	Typical	Max	Unit	Notes
Transmitter						
Centre Wavelength	λ_c	1530	1550	1570	nm	

Spectral Width (RMS)	$\Delta\lambda$			1	nm	
Average Output Power	P _{out}	-9		-3	dBm	1
Extinction Ratio	ER	8			dB	
Optical Rise/Fall Time (20%~80%)	tr/tf			0.16	ns	
Data Input Swing Differential	V _{IN}	400		1800	mV	2
Input Differential Impedance	Z _{IN}	90	100	110	Ω	
TX Disable	Disable		2.0	V _{cc}	V	
	Enable		0	0.8	V	
TX Fault	Fault		2.0	V _{cc}	V	
	Normal		0	0.8	V	
Receiver						
Centre Wavelength	λ_c	1290	1310	1330	nm	
Receiver Sensitivity				-23	dBm	3
Receiver Overload		-3			dBm	3
LOS De-Assert	LOS _D			-24	dBm	
LOS Assert	LOS _A	-35			dBm	
LOS Hysteresis		1		4	dB	
Data Output Swing Differential	V _{out}	700		900	mV	4
LOS	High	2.0		V _{cc}	V	
	Low			0.8	V	

NOTES

1. The optical power is launched into SMF.
2. PECL input, internally AC-coupled and terminated.
3. Measured with a PRBS 2⁷-1 test pattern @1250Mbps, BER $\leq 1 \times 10^{-12}$.
4. Internally AC-coupled.

TIMING AND ELECTRICAL

Parameter	Symbol	Min	Typical	Max	Unit
Tx Disable Negate Time	t _{on}			1	ms

Tx Disable Assert Time	t_off			10	μs
Time To Initialize, including Reset of Tx Fault	t_init			300	ms
Tx Fault Assert Time	t_fault			100	μs
Tx Disable To Reset	t_reset	10			μs
LOS Assert Time	t_loss_on			100	μs
LOS De-assert Time	t_loss_off			100	μs
Serial ID Clock Rate	f_serial_clock			400	KHz
MOD_DEF (0:2)-High	V _H	2		V _{cc}	V
MOD_DEF (0:2)-Low	V _L			0.8	V

DIAGNOSTICS

Parameter	Range	Unit	Accuracy	Calibration
Temperature	0 to +70	°C	±3°C	Internal / External
	-40 to +85			
Voltage	3.0 to 3.6	V	±3%	Internal / External
Bias Current	0 to 100	mA	±10%	Internal / External
TX Power	-9 to -3	dBm	±3dB	Internal / External
RX Power	-23 to -3	dBm	±3dB	Internal / External

DIGITAL DIAGNOSTIC MEMORY MAP

The transceivers provide serial ID memory contents and diagnostic information about the present operating conditions by the 2-wire serial interface (SCL, SDA).

The diagnostic information with internal calibration or external calibration all are implemented, including received power monitoring, transmitted power monitoring, bias current monitoring, supply voltage monitoring and temperature monitoring.

The digital diagnostic memory map specific data field defines as following.

2 wire address 1010000X (A0h)

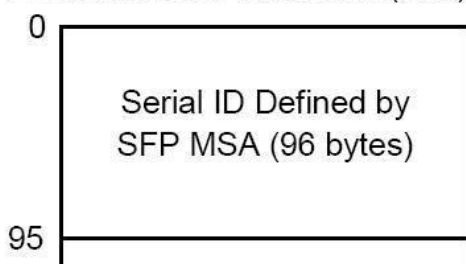

2 wire address 1010001X (A2h)

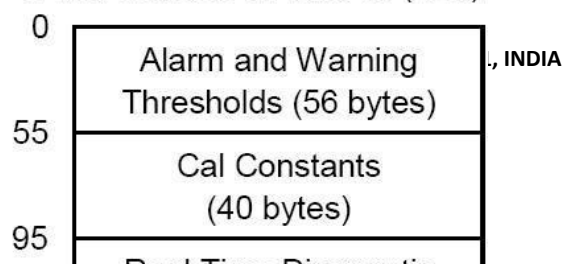

PIN DEFINITIONS

Pin Diagram

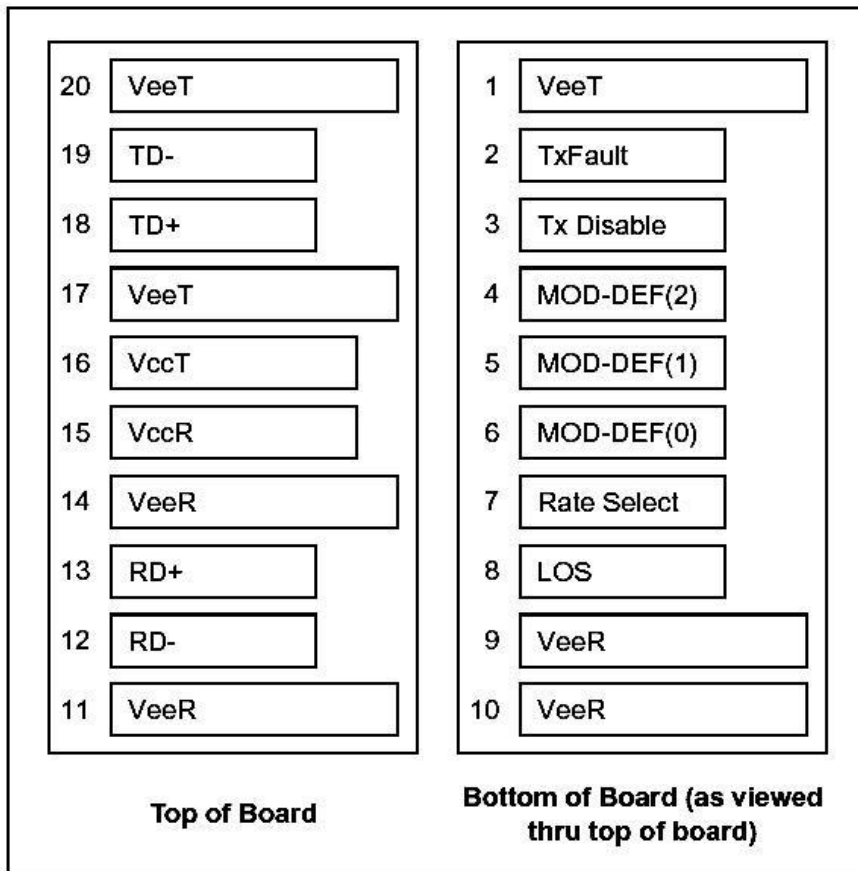

PIN DESCRIPTIONS

Pin	Signal Name	Description	Plug Seq.	Notes
1	V _{EET}	Transmitter Ground	1	
2	TX FAULT	Transmitter Fault Indication	3	Note 1
3	TX DISABLE	Transmitter Disable	3	Note 2
4	MOD_DEF(2)	SDA Serial Data Signal	3	Note 3
5	MOD_DEF(1)	SCL Serial Clock Signal	3	Note 3
6	MOD_DEF(0)	TTL Low	3	Note 3
7	Rate Select	Not Connected	3	
8	LOS	Loss of Signal	3	Note 4
9	V _{EER}	Receiver ground	1	
10	V _{EER}	Receiver ground	1	
11	V _{EER}	Receiver ground	1	
12	RD-	Inv. Received Data Out	3	Note 5
13	RD+	Received Data Out	3	Note 5
14	V _{EER}	Receiver ground	1	
15	V _{CCR}	Receiver Power Supply	2	
16	V _{CCT}	Transmitter Power Supply	2	
17	V _{EET}	Transmitter Ground	1	
18	TD+	Transmit Data In	3	Note 6
19	TD-	Inv. Transmit Data In	3	Note 6
20	V _{EET}	Transmitter Ground	1	

NOTES

Plug Seq.: Pin engagement sequence during hot plugging.

- TX Fault is an open collector output, which should be pulled up with a 4.7k~10kΩ resistor on the host board to a voltage between 2.0V and V_{cc}+0.3V. Logic 0 indicates normal operation; Logic 1 indicates a laser fault of some kind. In the low state, the output will be pulled to less than 0.8V.
- TX Disable is an input that is used to shut down the transmitter optical output. It is pulled up within the module with a 4.7k~10kΩ resistor. Its states are:
Low (0 to 0.8V): Transmitter on
(>0.8V, < 2.0V): Undefined
High (2.0 to 3.465V): Transmitter Disabled Open: Transmitter Disabled
- Mod-Def 0, 1,2. These are the module definition pins. They should be pulled up with a 4.7k~10kΩ resistor on the host board. The pull-up voltage shall be V_{ccT} or V_{ccR}.
Mod-Def 0 is grounded by the module to indicate that the module is present Mod-Def 1 is the clock line of two wire serial interface for serial ID
Mod-Def 2 is the data line of two wire serial interface for serial ID
- LOS is an open collector output, which should be pulled up with a 4.7k~10kΩ resistor. Pull up voltage between 2.0V and V_{cc}+0.3V. Logic 1 indicates loss of signal; Logic 0 indicates normal operation. In the low state, the output will be pulled to less than 0.8V.
- RD-/+ : These are the differential receiver outputs. They are internally AC-coupled 100 differential lines which should be terminated with 100Ω (differential) at the user SERDES.

Anda Telecom Pvt. Ltd.

Registered office : E-38, Sec 06, Noida, Gautambudha Nagar, Uttar Pradesh - 201301, INDIA

Phone : +91 120 4109590, +91 98716 50366

E-mail : Info@andatelecom.com URL : www.andatelecom.com

6. TD-/+ : These are the differential transmitter inputs. They are internally AC-coupled, differential lines with 100Ω differential termination inside the module.

RECOMMENDED INTERFACE CIRCUIT

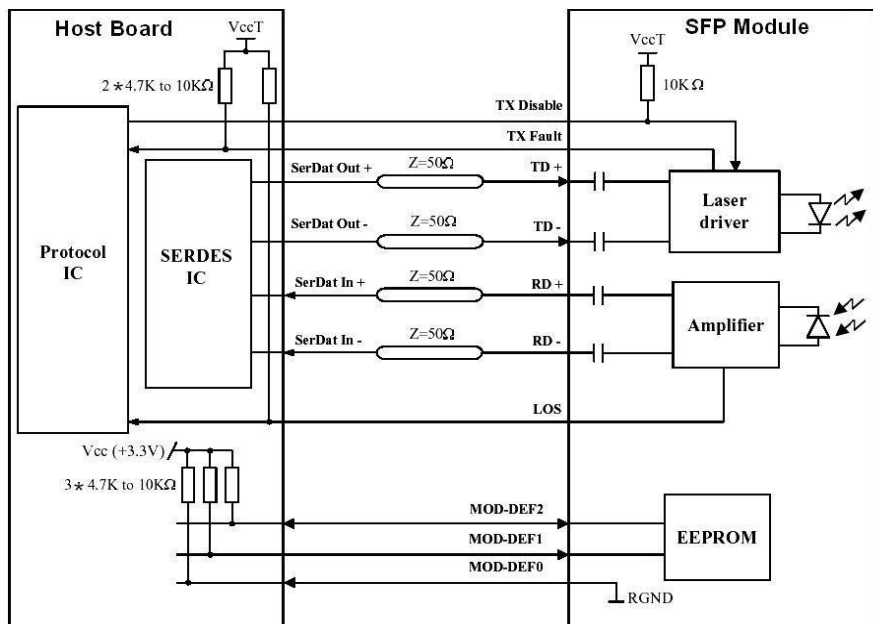

MECHANICAL DIMENSIONS

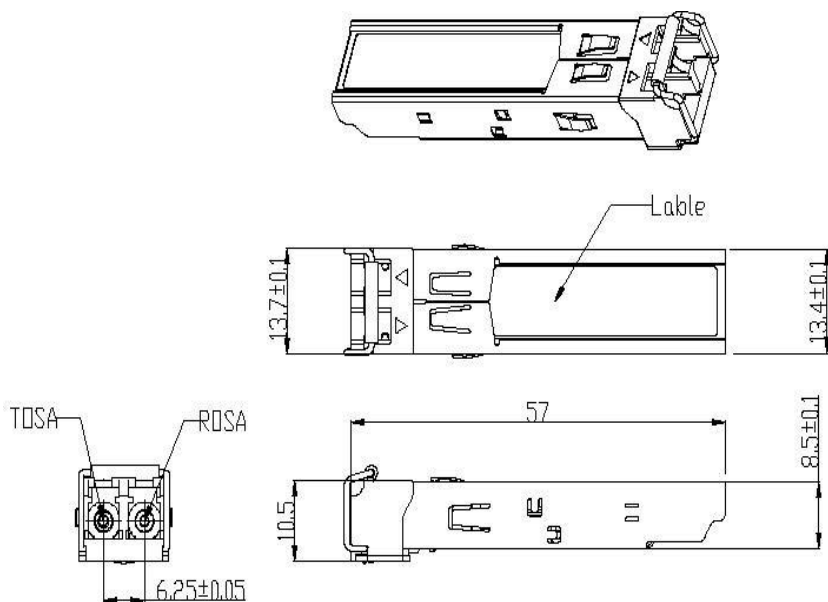

ORDERING INFORMATION

Anda Telecom Pvt. Ltd.
 Registered office : E-38, Sec 06, Noida, Gautambudha Nagar, Uttar Pradesh - 201301, INDIA
 Phone : +91 120 4109590, +91 98716 50366
 E-mail : Info@andatelecom.com URL : www.andatelecom.com

Model No.	Product Description
AT-SFP-B1253L-20	1.25Gbps, TX1550nm/RX1310nm, LC, 20km, 0°C ~ +70°C, with DDM
AT-SFP-B1253L-20I	1.25Gbps, TX1550nm/RX1310nm, LC, 20km, -40°C ~ +85°C, with DDM

ORDERING INFORMATION: -

<p>Anda Telecom Pvt. Ltd. Registered Office: PLOT NO 38, BLOCK E, -, Sector 6, Noida, Gautambuddha Nagar, Uttar Pradesh, 201301</p> <p>India.</p>	  	<p>https://andatelecom.com/</p> <p>+91 120 4109590 + 91 98716 50366</p> <p>info@andatelecomindia.com</p>
---	---	---